

## Pyro Safety Switches

Prevention in milliseconds to avoid short-circuits, fire ignition & battery draining.

### Pyro Safety Switch PSS-6

Autoliv's industry-standard Pyro Safety Switches comply with the high-quality requirements of the vehicle industry. Our Pyro Safety Switches offer a range of technical specifications, including different voltages, short circuit resistance and maximum current.

- Highly reliable over vehicle lifetime
- Robust design, solid standby operation
- Safe crowbar connection based on proven airbag technology
- Stable and reliable contact
- Flameless



### Product specifications

#### Voltage

Rated voltage 450 V

#### Current

Maximum short circuit current 5 kA / 5 ms + 600 A / 60 s

#### Busbar

Contact raw-material (base) CuSn 0,15  
Contact plating material (lead-free) Ni/Ag

#### Busbar profile

Cross-section nominal 38 mm<sup>2</sup>

#### Operation time

Release time < 1 ms

#### Resistance & Insulation data

Busbar resistance (at RT)  
before ops.  $\geq 10 \text{ M}\Omega$   
after ops.  $\leq 0,3 \text{ m}\Omega$

#### Typical applications

The closing device "crowbars" or short-circuits the two Fuel Cell terminals in less than three milliseconds. This consumes Hydrogen contained in the Fuel Cell and makes it safe. It can be used as a relay to activate any electrical system or discharge capacitors from DC-DC converters.

#### Triggering conditions

Qualified acc. to AK-LV 16 & USCAR  
Triggering circuit resistance  $\geq 1,7 \Omega$  and  $\leq 2,5 \Omega$   
Triggering current 1,75 A / 0,5 ms  
Or 1,20 A / 2,0 ms  
No-triggering current  $\leq 0,4 \text{ A}$   
Or  $\leq 5,0 \text{ A} / \leq 4 \mu\text{s}$   
Diagnostic current:  $< 100 \text{ mA}$   
Triggering pulse slope  $> 8 \text{ mA} / \mu\text{s}$

#### Temperature

Operating temperature  $-40^\circ\text{C} \dots + 105^\circ\text{C}$   
Environmental temperature  $-40^\circ\text{C} \dots + 105^\circ\text{C}$   
Storage temperature  $-40^\circ\text{C} \dots + 90^\circ\text{C}$

#### Other Data

Vibration resistance acc. to LV 124  
Mech. Shock resistance acc. to LV 124  
Temperature cycle resistance acc. to LV 124  
Chemical loads resistance acc. to LV 124

Other No ionizing gases / No particles exhaust

#### Terminal type

on bus-bar M8 screw  
on initiator ABX-5

ISO 19072-1 and -5 compliant  
(sealed and un-sealed)

#### Weight

80 g

## Technical Data & Dimensions

### Short circuit example

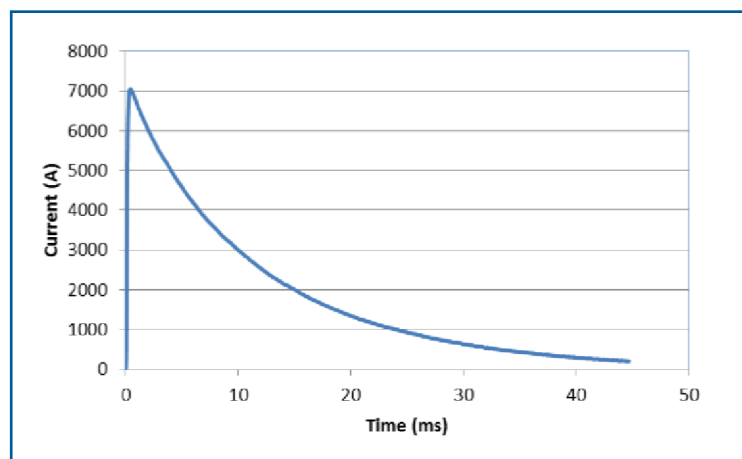

### Dimensions

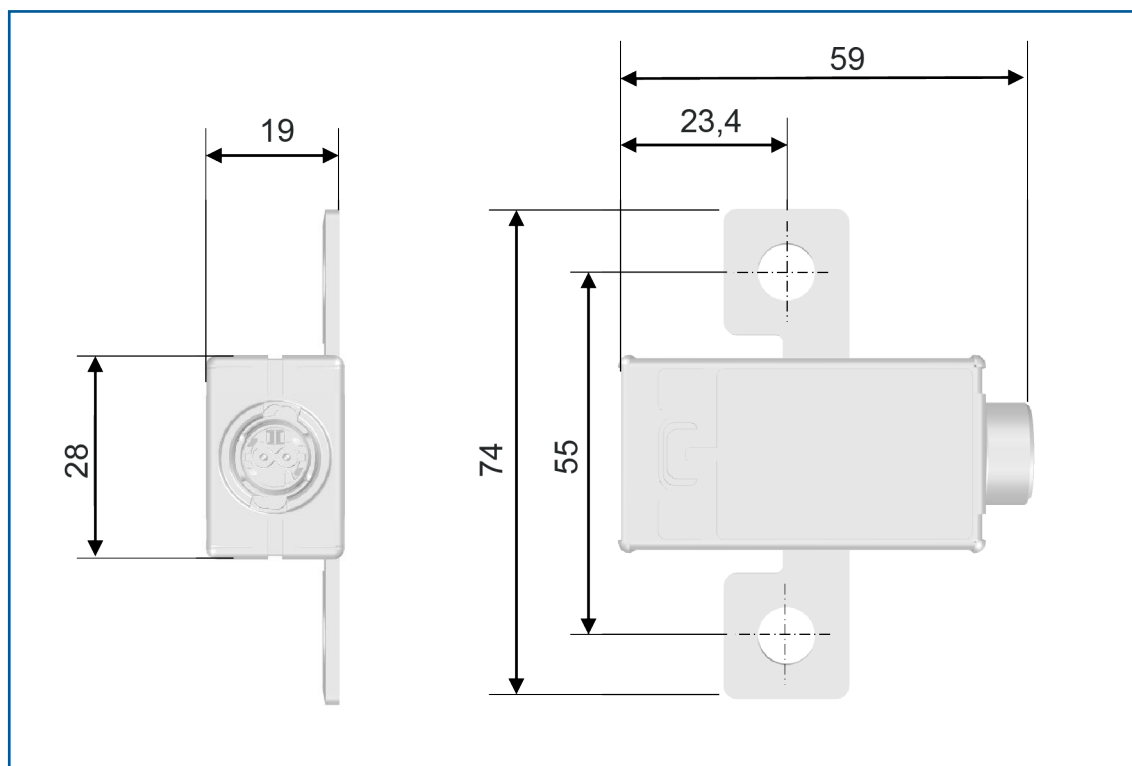

We refer emphatically to the fact, that all details mentioned, especially the application and utilization recommendation for the products and their system accessories, have been developed under normal conditions, and based on our knowledge and experience. Appropriate storage and usage of the products are assumed. A warranty or reliability of a finished project cannot be deduced because of varying materials, substrates and differing work conditions, neither by any indications nor from verbal statements, irrespective of any legal positions. For the possible accusation that FDT acted intentionally or grossly negligent, the user has to supply evidence that they provided Autoliv with all information and details necessary for an appropriate and correct evaluation through Autoliv in written form, immediately available and complete. The user is responsible for ensuring that the products are suitable for the given application. It is Autoliv's right to change product specifications without notice. Property rights of third parties are to be considered. In addition our particular sales and delivery terms are valid. The latest version of our product data sheet is obligatory, which can be requested directly through Autoliv. All information as well as all technical and drawing data comply with current technical standards and are based on our experience. National standards and regulations must be observed. Technical changes reserved. As of January 2016. © 2016



Pyro Safety Switch

autoliv.com